

ECLIPSE INFORMATION GUIDE

IMMERSO-PAK® BURNERS

Models 16 & 20 “IP”

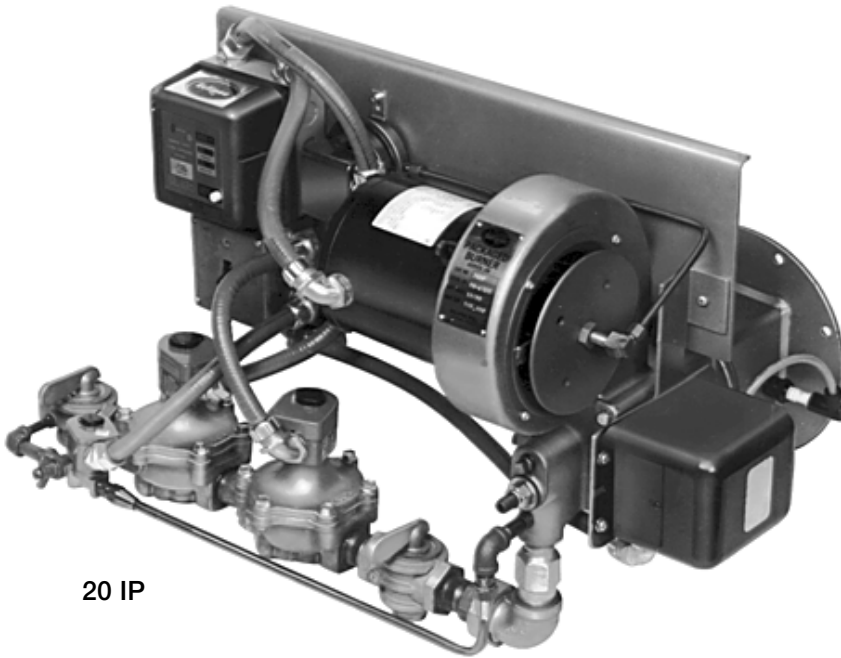

20 IP

- For 4, 5, & 6" immersion tubes.
- Easy to install and operate.
- Rugged construction for long life in industrial environments.
- Low maintenance.
- Low noise levels.
- Electronic flame monitoring.
- Two automatic gas shut-off valves.
- Air flow proving switch.
- 100% factory tested and adjusted.

WARNING

The burners covered in this Guide are designed to mix fuel with air and burn the resulting mixture. All fuel burning devices are capable of producing explosions and fires when improperly applied, installed, adjusted, controlled, or maintained. This Guide will provide information for using these burners for their limited design purpose. Do not deviate

from any instructions or application limits in this Guide without written advice from the Eclipse Combustion Division in Rockford, Illinois. Read this entire Guide before attempting to light burners. If you do not understand any part of the information in this Guide, contact your local Eclipse representative or Eclipse Combustion before proceeding further.

Important Notices About Safe Burner Operation

1. Store the burner inside. Exposure to the elements can damage the burner.
2. Adjustment, maintenance, and troubleshooting of the mechanical parts of this unit should be done by people with good mechanical aptitude and experience with combustion equipment.
3. Order replacement parts from Eclipse Combustion only. Any customer-supplied valves or switches should carry UL, FM, CSA, and/or CGA approval where applicable.
4. The best safety precaution is an alert and competent operator. Thoroughly instruct new operators so they demonstrate an adequate understanding of the equipment and its operation. Regular retraining must be scheduled to maintain a high degree of proficiency. The operator must have easy access to this Information Guide at all times.



ECLIPSE COMBUSTION

1.0 Applications

IP burners are complete assemblies ideal for heating immersion tubes on cleaning tanks, spray washers, salt baths, quenching tanks, tempering tanks, and similar equipment.

2.0 Specifications

Maximum Inputs—Natural gas only. LP gases must not be used.

16 IP	300,000 Btu/hr.	87.9 kw
20 IP	500,000 Btu/hr.	146.5 kw

Immersion Tube I.D.	16 IP	4" & 5"	102 mm & 127 mm
	20 IP	5" & 6"	127 mm & 152 mm

Maximum Flame Lengths	16 IP	8'	2.44 m
	20 IP	11'	3.35 m

Gas Inlet Pressures At valve train inlet	Minimum		Maximum	
	8" w.c.	19.9 mbar	14" w.c.	34.8 mbar
Supply pressure must be steady. Install a regulator if necessary.				

Electrical Supply 120 VAC, 1 cycle, 60 hz.

Motor Type 1/6 hp, 3600 rpm, TEFC, with built-in overload protection.

Firing Chamber Limits Operates best with neutral pressure at exhaust end of immersion tube.

Ambient Temperature Limits -40° to +104° F (-40° to +40° C)

Materials	Burner Body:	Cast iron
	Blower Housing:	Cast iron.
	Impeller:	Steel.

Net Weight	16 IP	68 pounds	30.8 kilograms
	20 IP	74 pounds	33.6 kilograms

Models	Burner	Assembly	Flame Monitor	Sensor	Sensor #
	16 IP	112256-00	None ¹	Flame rod	13312
	16 IP	112256-33	Eclipse 5605-33	Flame rod	13312
	16 IP	112256-01	Honeywell RA-890F	Flame rod	13312
	16 IP	112256-32	Eclipse 5605-32	UV scanner	10939
	16 IP	112256-02	Honeywell RA-890G	UV scanner	16281
	20 IP	112267-00	None ¹	Flame rod	13312
	20 IP	112267-33	Eclipse 5605-33	Flame rod	13312
	20 IP	112267-01	Honeywell RA-890F	Flame rod	13312
	20 IP	112267-32	Eclipse 5605-32	UV scanner	10939
	20 IP	112267-02	Honeywell RA-890G	UV scanner	16281

¹Burners ordered less relay include a flame rod, ignition plug, ignition transformer, and ignition cable. The customer must supply and install a suitable flame monitoring relay and base meeting local and/or insurance requirements.

Flame monitoring equipment supplied with these burners by Eclipse may or may not meet local safety and/or insurance requirements. The owner/user and/or his insurance underwriter must assume responsibility for the acceptance, use, and proper maintenance of flame supervision, limit controls, and other safety devices.

Figure 1—Dimensions & Parts List

16 & 20 IP Burners

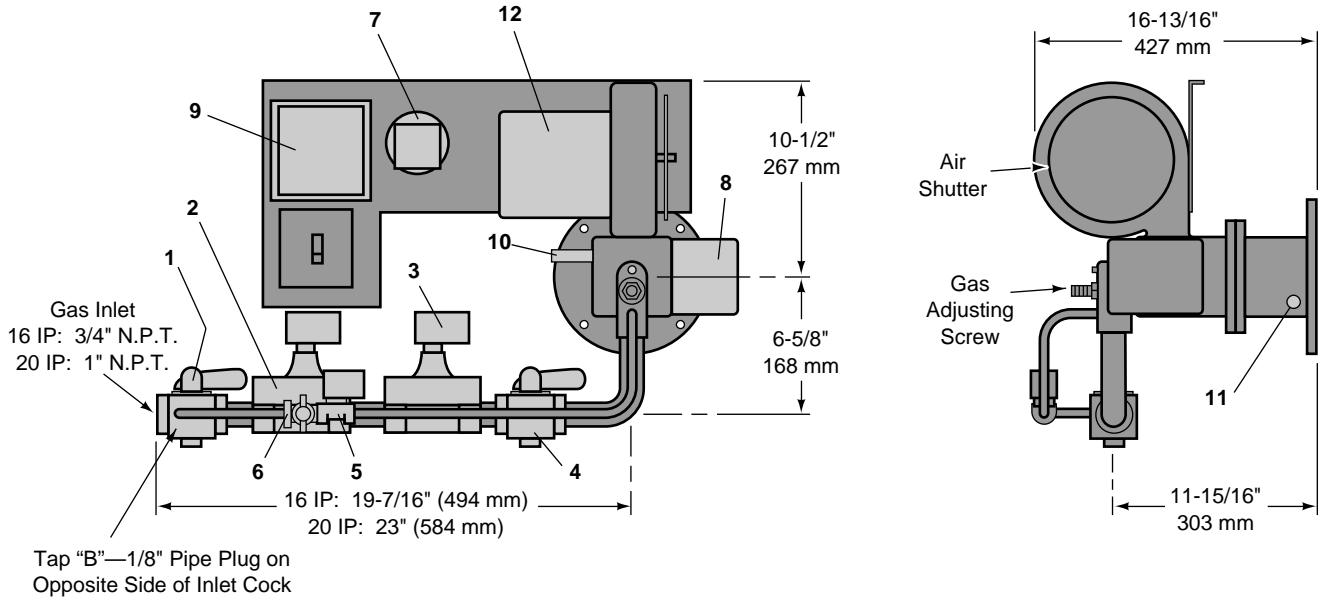

Mounting Flange Detail

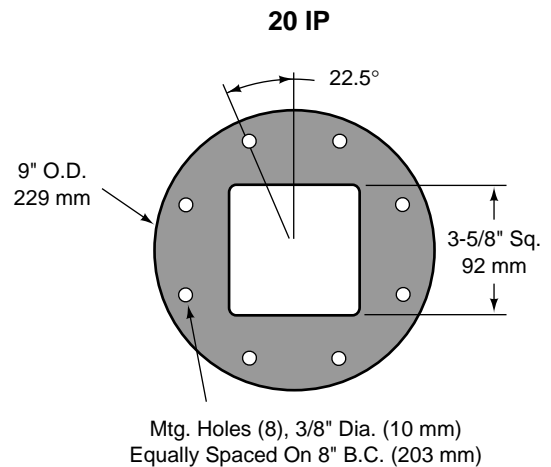
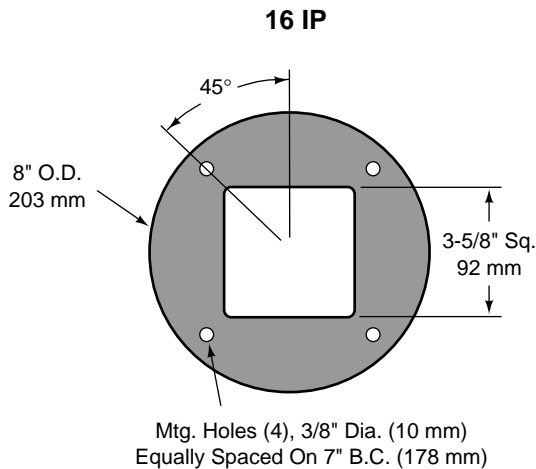

Item	Function	Description	16 IP	20 IP
1	Manual Gas Cock	Essex	12961	19122
2	Automatic Gas Shut-Off	Eclipse Solenoid	16728-5	13250
3	Automatic Gas Shut-Off	Eclipse Solenoid	16728-5	13250
4	Manual Gas Cock	Essex	12961	19122
5	Automatic Pilot Valve	Eclipse Solenoid	16728-1	16728-1
6	Adjustable Pilot Cock	---	12659	12659
7	Air Flow Switch	SMDF-12C133	14494	14494
8	Ignition Transformer Burner w/RA-890G All other burners	1/2 Wave Transformer 612-6A020E	13551 12178	13551 12178
9	Flame Monitor	See model under "Specifications."		
10	Flame Sensor			
11	Spark Plug	---	17071	17071
12	Blower Motor	See "Specifications"	12995	12995

Figure 2—JIB Wiring Diagrams

Eclipse 5605

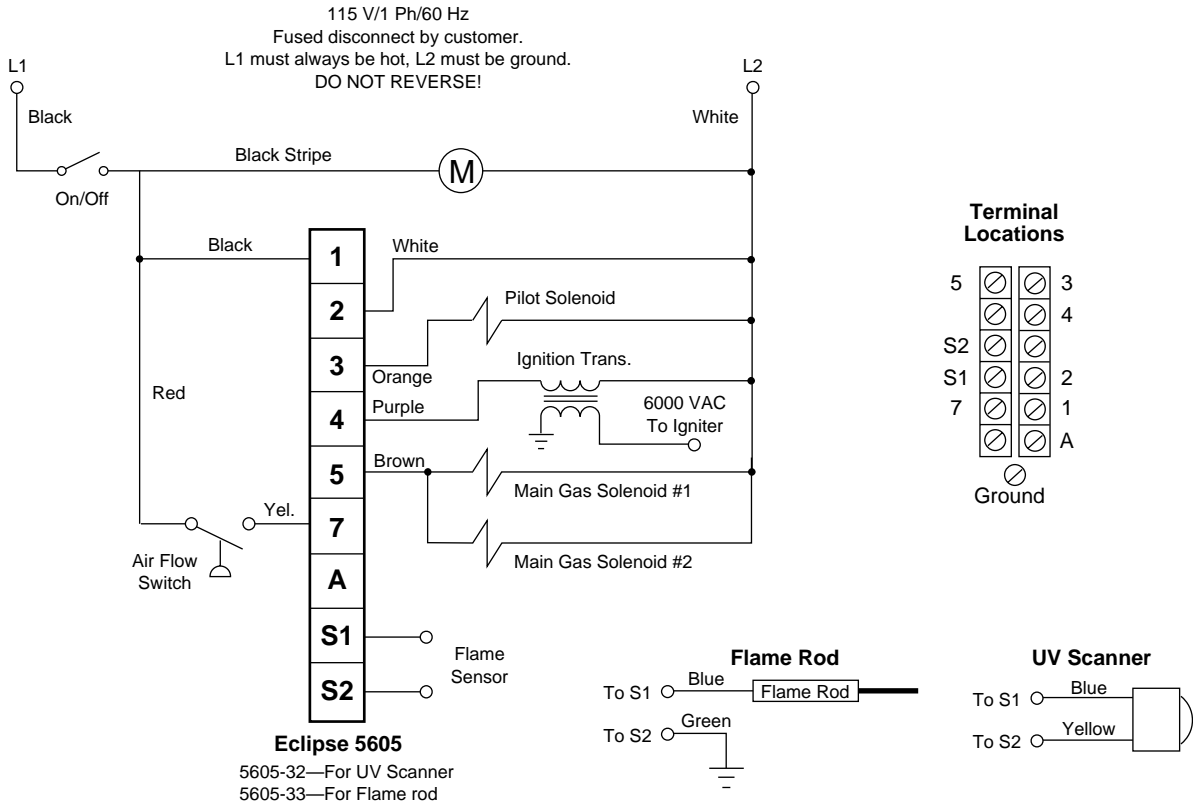

Honeywell RA-890

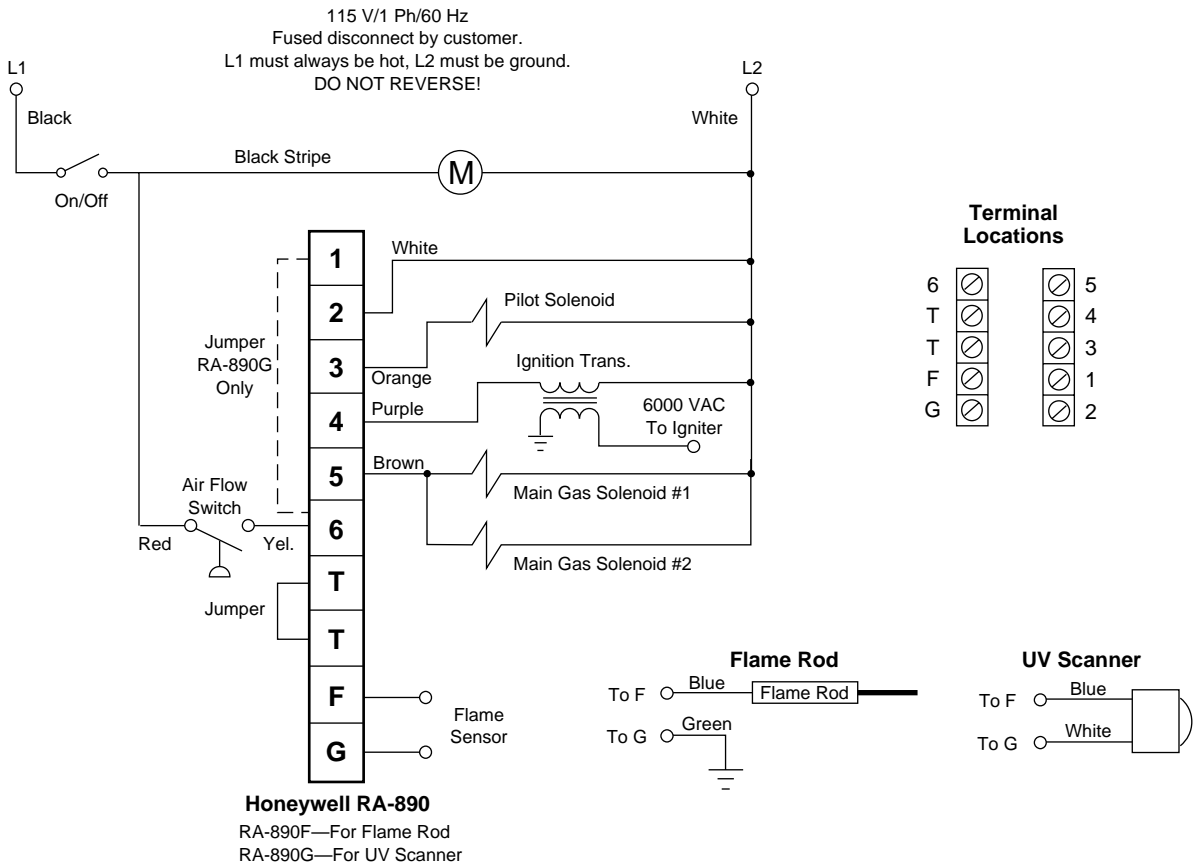
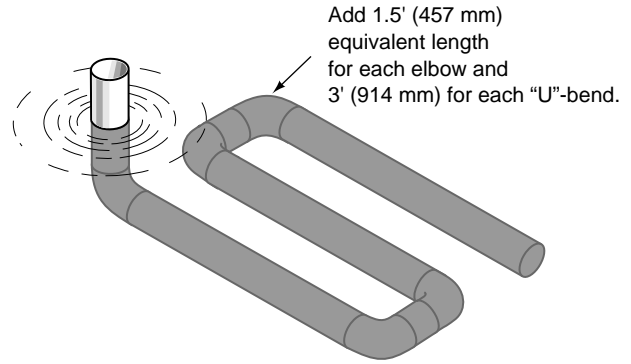

Figure 3—Immersion Tube Design

1. Use no more than five elbows.
2. Use standard or sweep elbows only; do not use miter elbows.
3. The first elbow must be at least ten tube diameters from the burner face.
4. The tube must be long enough to allow complete combustion before flue gases reach the exhaust stack. See the table below for recommended tube lengths.



Typical Immersion Tube with Five Standard Elbows

Recommended Tube Lengths for Various Efficiencies

Burner @ Max. Input		16 IP @ 300,000 Btu/hr (87.9 kw)						20 IP @ 500,000 Btu/hr (146.6 kw)					
Tube ID		4" (102 mm)			5" (127 mm)			5" (127 mm)			6" (152 mm)		
Efficiency		50%	60%	70%	50%	60%	70%	50%	60%	70%	50%	60%	70%
Tube Length ¹	feet	11	14	18	9.5	12	15.5	18	21	25	16	18	22.5
	meters	2.35	4.27	5.49	2.90	3.66	4.72	5.49	6.40	7.62	4.88	5.49	6.86
Net Heat Out	1000's Btu/hr.	150	180	210	150	180	210	250	300	350	250	300	350
	kw	44.0	52.8	61.6	44.0	52.8	61.6	73.3	87.9	102.6	73.3	87.9	102.6

¹ Equivalent length based on straight length plus extra for elbows or "U"-bends as shown in the illustration above. Tube lengths are for the listed efficiencies with the corresponding burner and maximum input. If desired, burner input, tube length, and net heat output may be reduced proportionally while maintaining the same efficiency.

Figure 4—Draft Breaking Hood

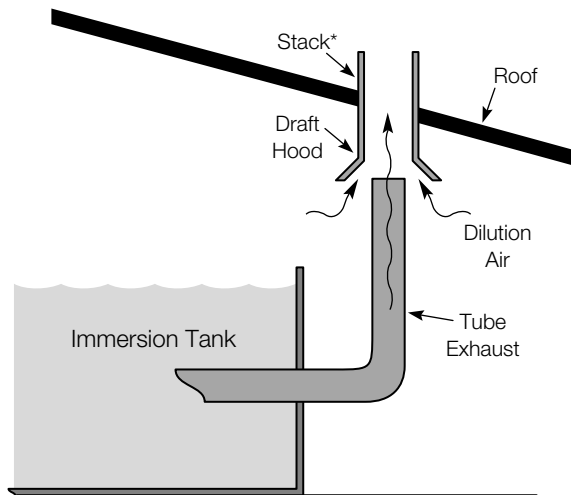

* At least one pipe size larger than the tube exhaust. See applicable codes for required size.

Leave space between the draft hood and exhaust pipe for possible installation of a damper plate to reduce tube rumbling. See Troubleshooting, page 8.

Figure 5—Burner Mounting

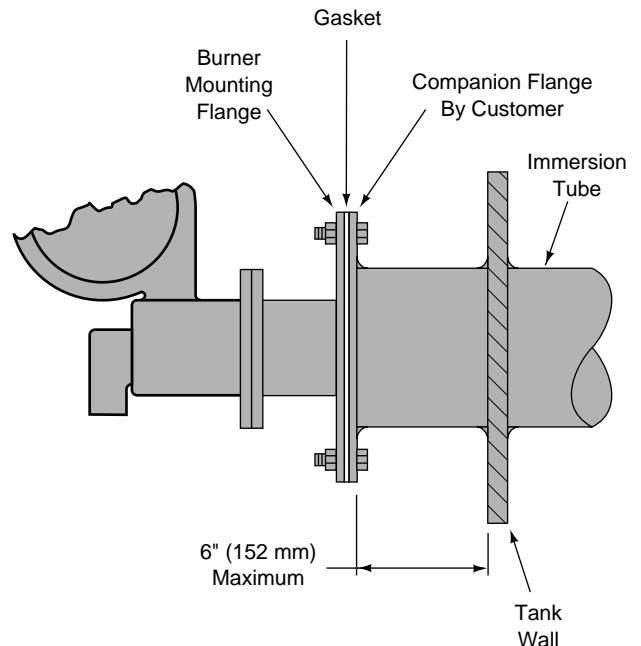

See Figure 1 for mounting flange dimensions.

3.0 Immersion Tube Design

WARNING

If improperly adjusted or operated, burners can produce toxic concentrations of gases, including carbon monoxide. Venting these products into confined, poorly ventilated areas is dangerous. To avoid this situation:

- Vent the appliance to the outdoors wherever feasible. See Step 3.4.
- Where equipment location or other considerations prevent outside venting, be sure that the building has adequate volume and fresh air makeup to dilute any potentially harmful combustion products down to safe levels as defined by OSHA or other authorities having jurisdiction.

3.4 Design Parameters

See Figure 3 for details of immersion tube design.

3.4 Tube Exhaust

See Figure 4 for proper exhaust design. The draft hood makes burner operation less susceptible to atmospheric conditions and lowers the temperature of flue gases as they pass through the building roof.

When multiple exhausts are manifolded together into a common stack, always use draft hoods and size the stack to handle the total exhaust flow from all the burners, plus dilution air. Failure to do so may permit cross feeding of pressure between tubes, causing pilot lighting difficulties, burner instability, and rumbling and popping.

All draft hood, flue collector and stack designs must conform to applicable codes.

3.5 Burner End Of Immersion Tube

The burner end of the immersion tube should extend no more than 6" from the tank wall. See Figure 5.

4.0 Installation

4.1 Burner Inspection

Make a thorough inspection of the burner when uncrating and before installing it. If any parts appear broken, bent, or damaged, contact your Eclipse representative or the Eclipse factory before installing the burner.

4.2 Burner Environment

Protect burners from the weather.

Combustion air should be free of contaminants which might corrode or plug the blower or burner's internal passages.

Provide access to the burners for inspection, maintenance and removal.

4.3 Burner Mounting

See Figure 5 for mounting details. The gasket must be compressed enough to provide an airtight seal.

For maximum service life of the automatic gas shut-off valves, mount the burner in the orientation shown in Figure 5.

4.4 Burner Piping

Connect the gas supply line to the burner and make certain the supply line is adequate in size. For long runs, the pipe size should be larger than the burner inlet to prevent excessive losses. Check with your gas company if in doubt.

For convenience in burner removal, Eclipse recommends installing a shutoff cock and suitable pipe union disconnect upstream of the burner.

Use flexible nipples on all gas connections. Solid piping may restrain the burner from normal thermal expansion and damage the burner or its piping com-

ponents. Do not use the burner assembly to support the piping.

Gas piping must comply with American National Standard "National Fuel Gas Code" (NFPA No. 54 or ANSI Z223.1)*, or must be acceptable to the authority having jurisdiction.

4.5 General Wiring Suggestions

The electrical supply must be 120 volt, 60 cycle, single phase AC. Make all electrical connections in accordance with the appropriate wiring diagram in Figure 2.

Do not disturb the factory installed wiring. Contact the Eclipse factory regarding special operating sequences and controls. Install suitable main disconnect switch and fuses at a convenient location. Be certain that the ignition cable is properly connected to the spark plug and the pilot ignition transformer.

Electrical wiring must comply with the National Electric Code*, (NFPA Std. 70 or ANSI-CI 1981), or must be acceptable to the authority having jurisdiction.

*Available from:

National Fire Protection Association
Batterymarch, Park
Quincy, MA 02269

American National Standard Institute
1430 Broadway
New York, NY 10018

5.0 Start-Up & Adjustment

CAUTION

These burners are factory-adjusted on natural gas and tagged with the correct pressure settings. If factory settings have been tampered with, field adjustment will be necessary. Follow the procedure below. These general instructions apply regardless of the type of flame monitoring relay installed. See the appropriate data sheets for specific information on the operation and sequencing of the particular relay installed on the burner.

- 5.1 Close the main manual gas cocks and the pilot gas cock and turn the burner On-Off switch "Off."
- 5.2 Loosen the lock nut on the gas adjusting screw (Figure 6). Using an allen wrench, turn the adjusting screw clockwise until it seats within the burner body. Then turn the screw counter-clockwise five full turns.
- 5.3 Open the air shutter approximately 3/4" .
- 5.4 Turn the handle of the adjustable pilot cock to the open position, Figure 7.
- 5.5 Turn the burner On-Off switch "On" to start the blower.
- 5.6 Once the air flow switch has proven blower operation, the flame monitoring control will be energized. The pilot solenoid valve will open and there will be a 15 second trial for ignition (TFI).
- 5.7 After the pilot ignites, adjust the pilot gas cock by removing the top screw, Figure 7. Turn the adjusting screw clockwise to reduce gas flow, and counter-clockwise to increase gas flow. When the desired setting is reached, replace the top screw.
- 5.8 The flame monitor will prove pilot operation and energize both main gas solenoid valves.
- 5.9 Open the main manual gas cocks. After the main flame is lit, use a flue gas analyzer to measure the percent oxygen in the exhaust. Adjust the air shutter to produce about 4% O₂ or 9.5% CO₂ with a stable, smoke-free flame. If smoke or instability persists with the air shutter fully open, close the gas adjusting screw as needed to achieve clean, stable operation. This may result in higher O₂ or lower CO₂ levels than those specified above.
- 5.10 When the burner is fully adjusted, lock the air shutter and gas adjusting screw in place.
- 5.11 If necessary, re-adjust the pilot setting to compensate for changes in the air shutter opening.
- 5.12 The burner can now be operated without further adjustment, using only the on-off switch.

Figure 6—Main Gas Adjusting Screw

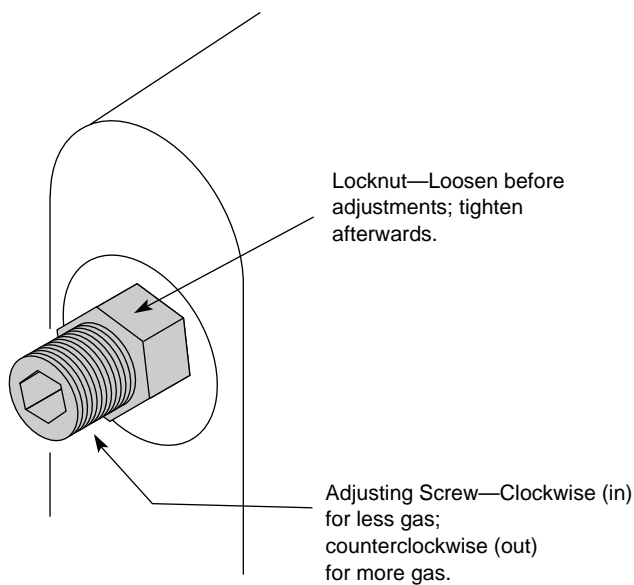

See Figure 1 for adjusting screw location.

Figure 7—Pilot Cock

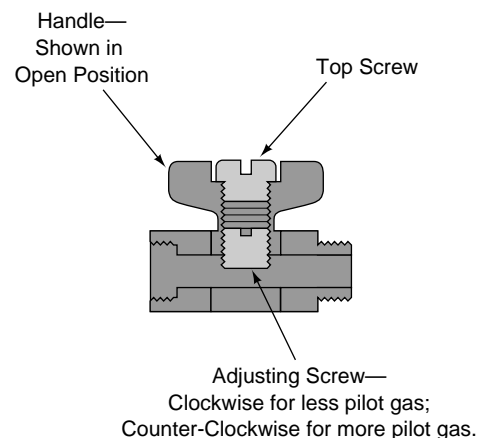

6.0 Trouble-Shooting

CAUTION

Trouble shooting of electrical circuits should be done by qualified plant electricians, technicians, or engineers experienced in all facets of this type of combustion equipment.

6.1 Pilot Fails to Light

- On initial start-up, gas line may be filled with air. Repeat ignition trial several times to purge.
- No power to ignition transformer or pilot solenoid.
- Open circuit between transformer and spark plug.
- Spark plug is dirty, wet, or improperly installed. See Figure 8.
- Pilot gas cock screw closed.
- Insufficient gas pressure at valve train inlet.

6.2 Main Flame Fails to Light

- Pilot set too lean, blows out as main flame comes on.
- Insufficient gas pressure at valve train inlet.
- Gas flow misadjusted. See Section 5.0.

6.3 Burner Behaves Erratically— Won't Respond to Adjustment

- Burner internals loose, dirty or burned out. Contact your Eclipse representative for service.
- Water in tube due to tube leak or condensation. Condensation will usually evaporate after a brief period of operation.

6.4 Burner is Unstable— Produces Smoke, Soot, or Excessive CO₂

Burner is misadjusted. See Section 5.0.

6.5 Burner Pulsates, Rumbles, or "Motorboats"

- Burner is misadjusted. See Section 5.0.
- Acoustic feedback from tube. This phenomenon is unpredictable, probably resulting from a combination of tube configuration, firing rate, stack conditions, and gas and air piping layout. Since the exact cause is unknown, there is no exact solution. However, these steps may help:

Restrict the tube exhaust. Slide a piece of steel plate over the end of the tube until the rumbling disappears. Then weld the plate in place. This restriction may require burner readjustment.

Increase gas pressure at the valve train inlet and reduce gas flow by turning the gas adjusting screw clockwise, Figure 6. This produces a higher pressure drop across valve train, which tends to dampen the effect of tube pressure pulsations.

- Air leakage between the burner and the immersion tube. Check that the burner flange gasket is intact and not leaking, and that the flange bolts are pulled down tight.
- Water in the burner or tube due to tube leakage or condensation. Condensation will usually evaporate after a brief period of operation.

7.0 Maintenance

7.1 Motor Lubrication

Oil the blower motor according to the manufacturer's instructions as printed on the motor label.

7.2 UV Scanner Maintenance

Periodically clean the UV scanner lens as described in the manufacturer's product literature.

7.3 Ignition Plug and Flame Rod Replacement

Ignition plugs and flame rods wear out over long periods of normal burner operation. Eclipse recommends that the user keep at least one of each in stock at all times to prevent nuisance shutdowns. See Figure 8.

Figure 8—Spark Plug Position

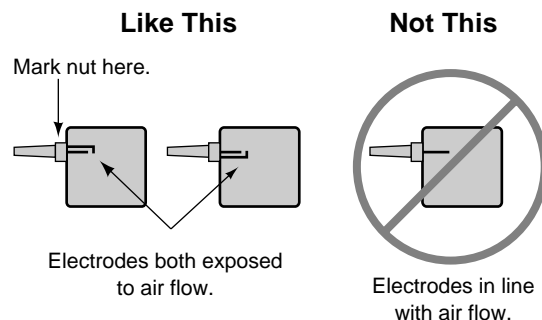

Before installing plug, mark the the nut to indicate the proper electrode position. Then tighten the plug until the mark is in the right place.



ECLIPSE COMBUSTION